

SLIDING DOCUMENT SYSTEMS



Secure transfers of documents and other items for a safer welcome

Document- / packet-handlers are integrated into work surfaces and provide the means to transfer documents, tickets, envelopes and packets between a secure area and an exterior area used by the general public. These document handlers are available in various dimensions and depths and enable larger items to be passed from one side to the other. Because of the way in which they are designed, they offer protection against vandalism, while other models are bullet-proof up to FB4 class, in accordance with the EN1522 standard.

This model is for transferring notes, coins or small documents to a secure area. It is designed to protect personnel against physical attacks. A validator can be installed with the “pre-drilled” model (display screen).

PMS IDF



Reference:

Drilled in A74055 PMS IDF
(for validator)

Non-drilled A74123 PMS IDF
A74147A PMS IDF V2

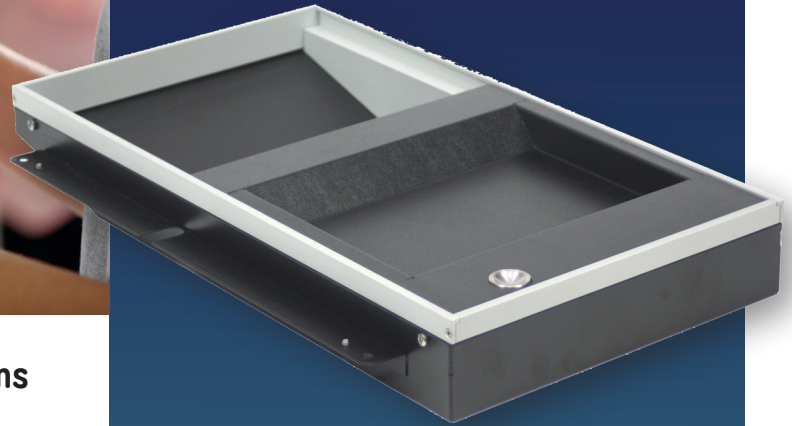

DO YOU KNOW?



Other models in the Sliding document-/packet-handling system range

- Sepac P52 and P140 (vandalism proof)
- Model 20 (FB4 level bullet-proof) with 100/200/400 mm deep compartments
- Model 30 (vandalism proof, FB4/ FB6 bullet-proof)

Specifications

PMS IDF

- Brushed silver aluminium frame
- Black textured sliding compartment with unlocking push-button
- Steel casing – Stainless steel screws and fastenings
- The “pre-drilled” model is designed to be installed with a SAGEM PP15 validator.
- Block-out: 45 x 142 mm
- Use: indoors
- Resistance: vandalism proof

Compatibility for installation with other Hygiaphone products:

- Aluminium Fichet doors and partitions
- Pay window

PMS IDF V2

Identical specifications, but different product dimensions.

Operation

- Manually-operated sliding compartment. This compartment is automatically locked in place as soon as it reaches its end stop on either the customer or employee side.
- It is unlocked by pressing the push-button

Installation

This note- / coin-handling system can be installed recessed into a reception desk or ticket exchange desk work surface.

Applications

- Amusement parks
- Reception desks
- Public authorities
- Foreign exchange desks
- Stations

Advantages

- Automatic locking of the sliding plates
- Option to recess a validator
- Small footprint
- Quick and easy to install

Dimensions

Dimensions (mm)	PMS IDF			PMS IDF V2		
	Overall	Compartment	Useful drawer capacity	Overall	Compartment	Useful drawer capacity
Height	65	65	26	65	65	26
Width	325	265	222	220	160	117
Depth	480	480	120	400	400	101
Weight (kg)	5.7			2.4		
Size of area to be reserved (H x L x P)	75 x 267 x 482 mm			75 x 162 x 402 mm		

Packaging

	PMS IDF	PMS IDF V
Weight of packaging + device	7.5 kg	4.5 kg
Packaging dimensions	530 x 390 x 120 mm	
Type of packaging	Carton	

Caractéristiques techniques

PMS IDF

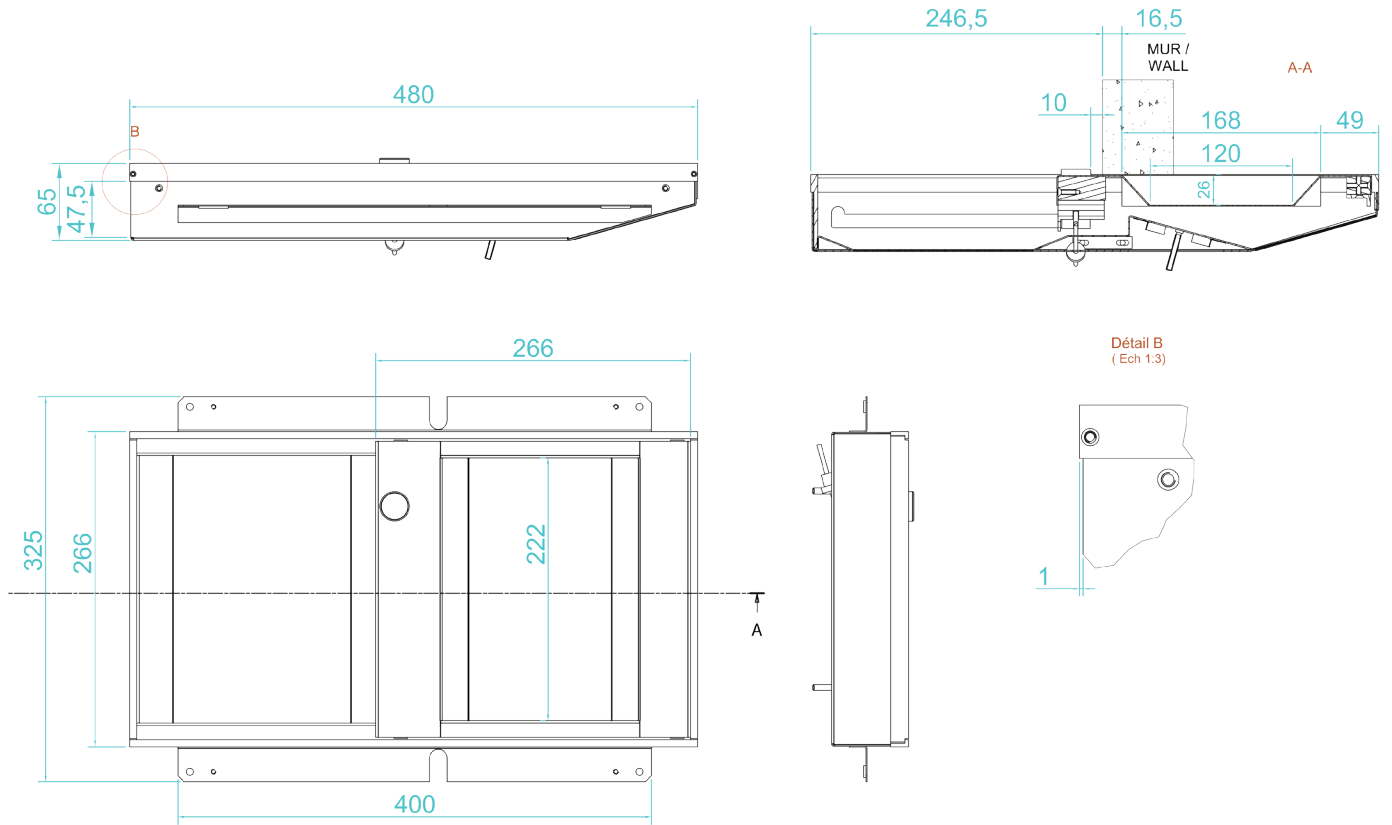

Caractéristiques techniques

PMS IDF V2

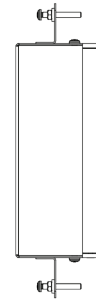
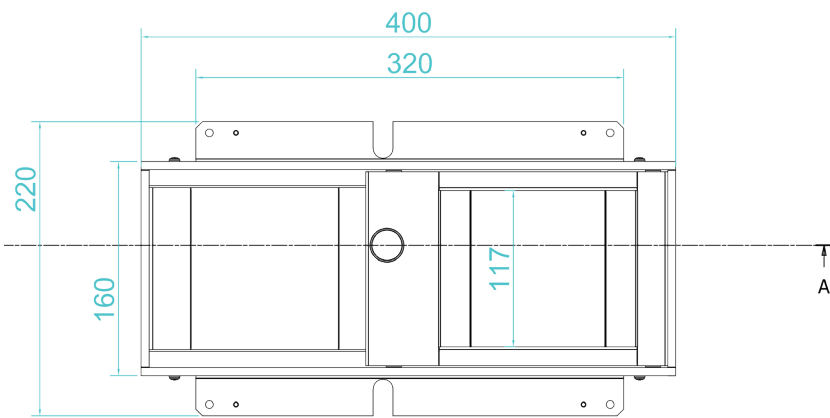
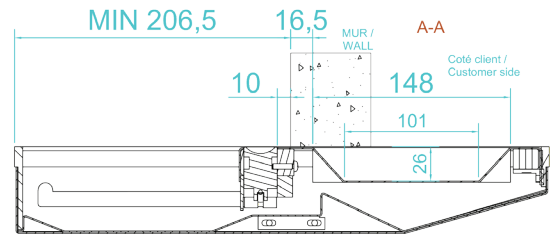
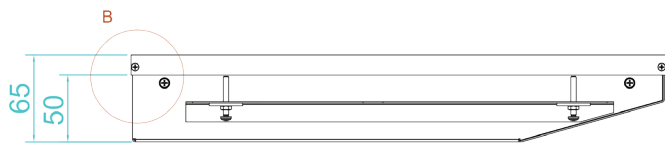

Détail B
(Ech 1:2)

