

COIN- / BANKNOTE- HANDLING SYSTEM



Secure transfers of documents and other items for a safer welcome

Note-/coin-handling systems can be installed with integrated pay windows or across glass facades. These models can be used for transferring coins, notes, tickets or small documents between a secure interior area and an exterior area used by the general public. Some of these banknote-handling systems can be surface-mounted onto reception desks and – because of the way in which they are designed – provide maximum protection against vandalism. Other models can be recessed into the work surface and can provide bullet-proof protection of up to FB7 (12 model).

This model can be used to transfer small documents, notes, coins and objects up to 33 mm high to a secure, area and has been designed to protect personnel against weapons attacks. FB4 or FB6 ballistic protection in accordance with the EN1522 standard. Optionally, this model can also be equipped with sound holes for better acoustic comfort.

MODEL 12



Reference:

A30203 banknote- / coin-handling system
Model 12 FB4

AVQ142 banknote- / coin-handling system
Model 12 FB6

A30205 banknote- / coin-handling system
Model 12 with sound holes

A30467 banknote- / coin-handling system
Model 12 FB7



DO YOU KNOW?

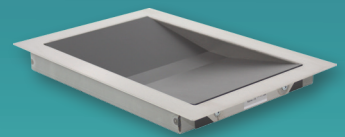

Other models in the coin- / banknote- handling system range

- Model 11 (vandalism proof)
- Duetto coin- / banknote-handling system (vandalism proof)

MODEL 12

Specifications

Model 12 FB4

- Stainless steel structure on a black steel box
- Interior brown-black RAL 8022 fixed plate made of a special material
- Can be integrated into a door, airlock or a Hygiaphone partition (Ref.: installation kit: A30402 – See manual A01364)
- Usage: indoors
- FB4-certified, meets the EN 1522 standard
- Allows the transfer of documents up to A4 format, height 30 mm

Model 12 FB6 / FB7

- Similar specifications but FB6 level of ballistic protection
- Usage: indoors
- FB6- or FB7- certified, meets the EN 1522 standard
- Allows the transfer of documents up to A4 format, height 30 mm

Model 12 PH

- Equipped with sound holes to communicate with your interlocutor

Compatibility for installation with other Hygiaphone products:

- Aluminium Hygiaphone doors and partitions
- UniSas EV
- This note-handling system can be supplemented with a pay window

Applications

- Embassies
- Reception desks
- Public authorities
- Foreign exchange desks

Advantages

- Aesthetic / stylish
- Comfort
- Quick and easy to install

Dimensions

Dimensions (mm)	Model 12 FB4			Model 12 FB6		
	Overall	Compartment	Int. tray capacity	Overall	Compartment	Int. tray capacity
Height	53	52	30	82	80	30
Width	416	372	335	412	396	335
Depth	354	319	225	352	334	225
Weight (kg)	7.5			23		
Size of area to be reserved (H x W x D)	53 x 377 x 328 mm Placed in the reservation			96 x 416 x 338 mm Placed in the reservation		

MODEL 12

Dimensions

Dimensions (mm)	Model 12 PH			Model 12 FB7		
	Overall	Compartment	Int. tray capacity	Overall	Compartment	Int. tray capacity
Height	71	69	30	82	80	30
Width	700	680	335	412	396	335
Depth	382	362	224	360	342	225
Weight (kg)	27			27		
Size of area to be reserved (H x W x D)	71 x 367 x 685 mm Placed in the reservation			96 x 416 x 346 mm Placed in the reservation		

Packaging

	Model 12 FB4	Model 12 PH	Model 12 FB6	Model 12 FB7
Weight of packaging + device	20 kg	60 kg	30 kg	36 kg
Packaging dimensions	710 x 540 x 300 mm	1200 x 800 x 400 mm	710 x 540 x 300 mm	710 x 540 x 300 mm
Packaging support	Disposable pallet			

MODEL 12

Technical specifications

Model 12 FB4

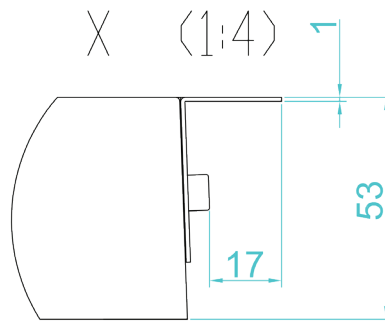
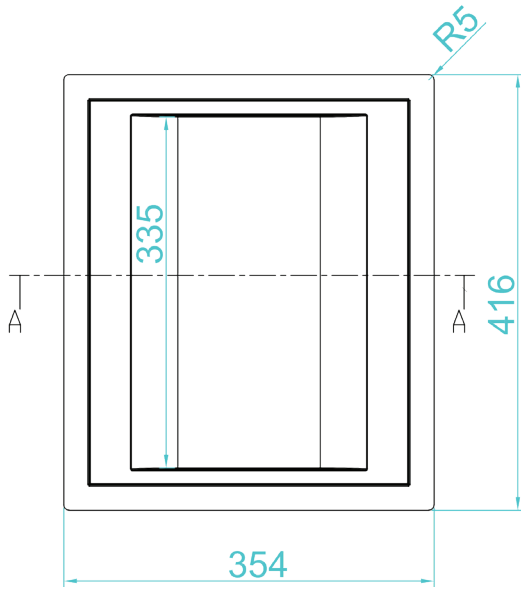
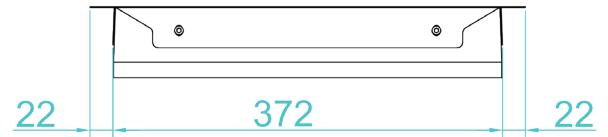
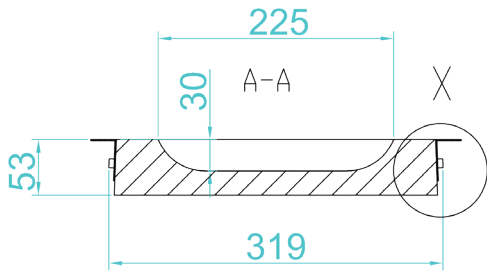

MODEL 12

Technical specifications

Model 12 FB6

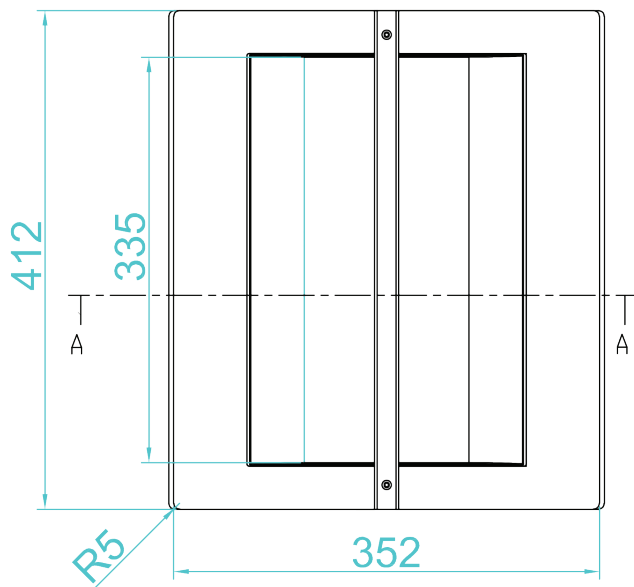
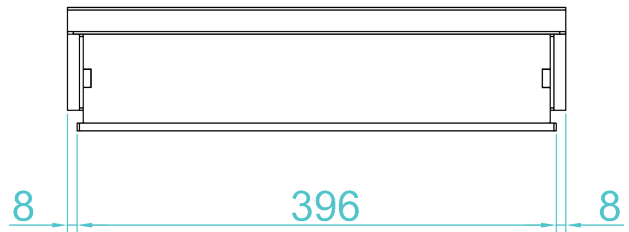
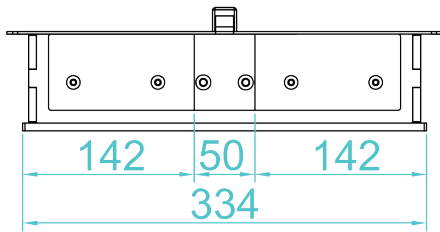
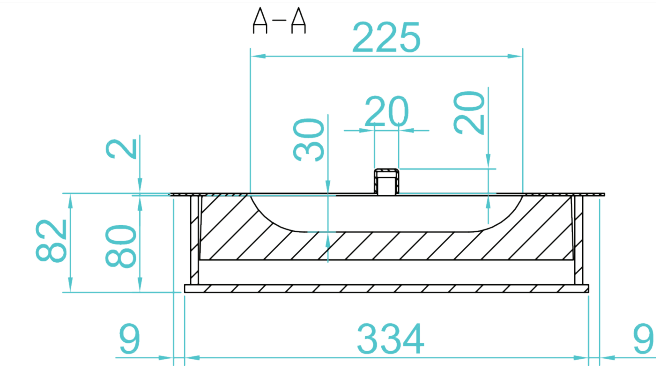

MODEL 12

Technical specifications

Model 12 FB7

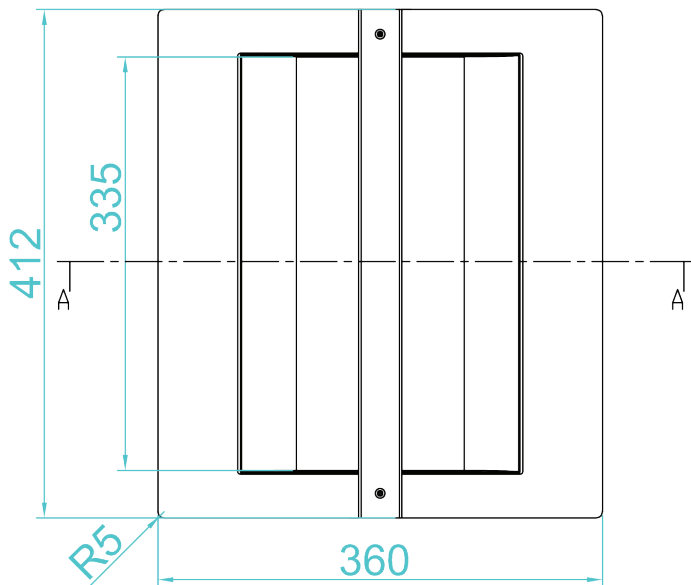
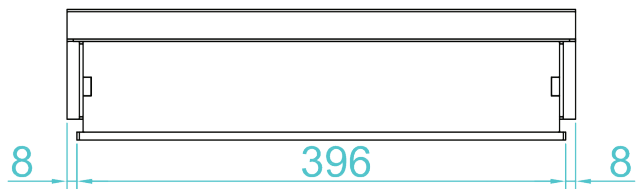
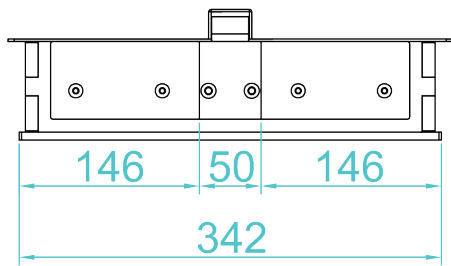
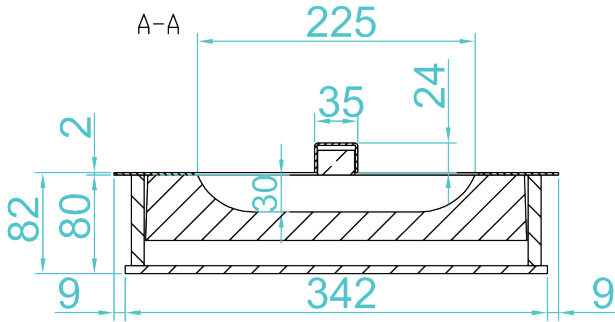

MODEL 12

Technical specifications

Model 12 PH

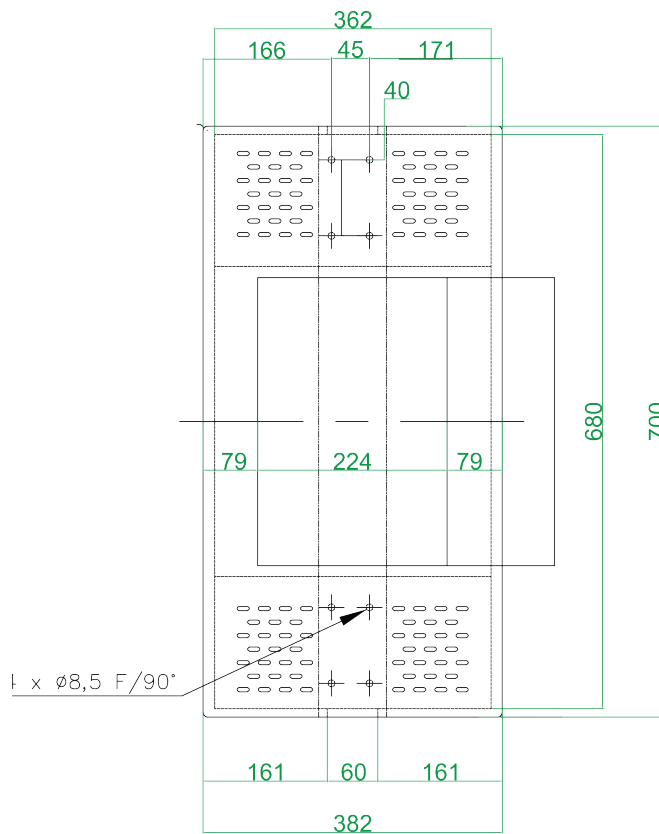
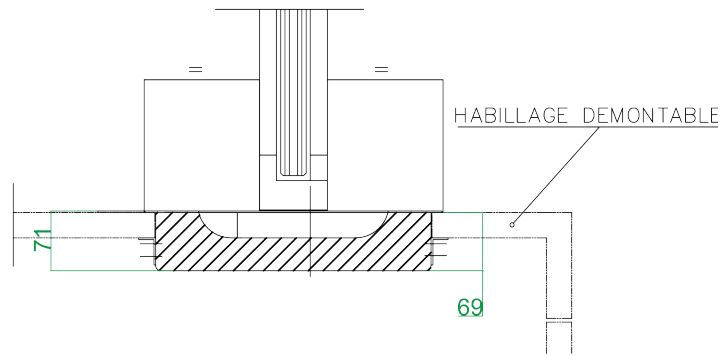

Installation

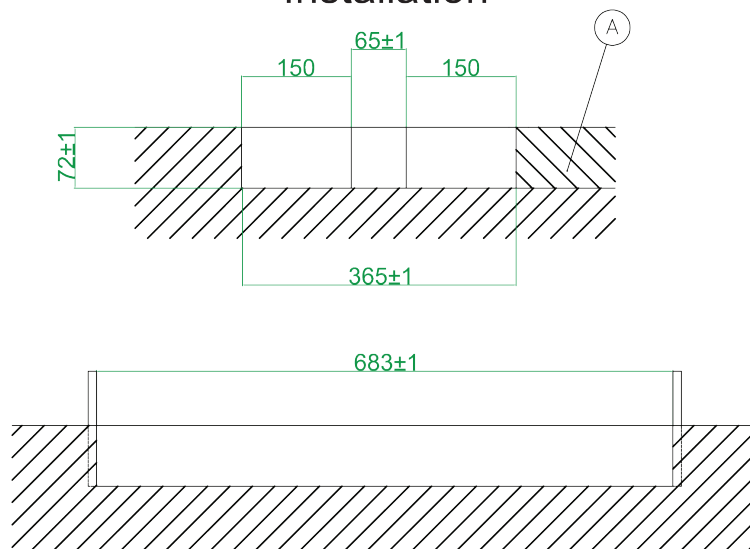



www.hygiaphone.fr

