

COIN- / BANKNOTE- HANDLING SYSTEM

MODEL 11

Reference:
A30457 Model 11

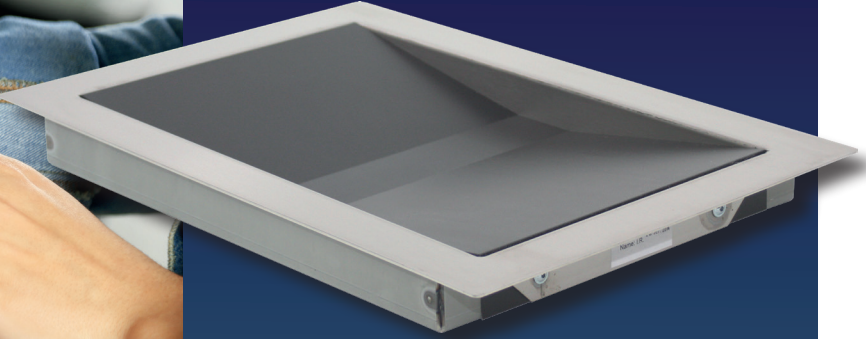

Secure transfers of documents and other items for a safer welcome

Banknote-/coin-handling systems can be installed with integrated pay windows or across glass façades. These models can be used for transferring coins, notes, tickets or small documents from a secure interior area to an exterior area used by the general public. Some of these banknote-handling systems can be surface-mounted onto reception desks and – because of the way in which they are configured – provide maximum protection against vandalism. Other models can be recessed into the work surface and can provide bullet-proof protection of up to FB6(model 12)

This model can be used for banknotes, coins, tickets and documents and can be fitted into glass façades or secure areas. This product is easy to integrate into a counter type work surface.

DO YOU KNOW?

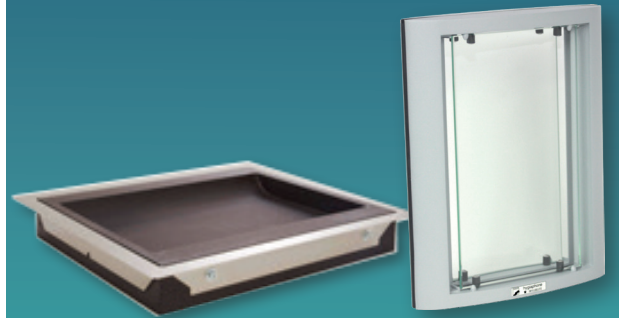

Other models in the coin- / banknote- handling system range (fixed tray)

- Duetto (vandalism proof)
- PT1 / PT2 (vandalism proof)
- Model 12 FB4 (bullet-proof)
- Model 12 FB6 (bullet-proof)

MODEL 11

Specifications

- Black skinplate tray
- 2 mm thick brushed steel frame
- Delivered assembled
- A4 size (210 mm x 297 mm)
- Can be recessed into a work surface.
- Use: indoors or outdoors (sheltered)
- Resistance: vandalism proof
- Compatible with pay windows

Applications

- Amusement parks
- Reception desks
- Public authorities
- Hospitals

Advantages

- Quick and easy to install
- Quality of finish
- Requires no maintenance or lubrication

Dimensions and packaging

Dimensions (mm)	Model 11	
	Overall	Useful width
Height	42	30
Width	320	240
Depth	480	
Weight (kg)	5.6	

Packaging

	Model 11
Weight of packaging + device	6 kg
Packaging dimensions	530 x 460 x 130 mm
Type of packaging	Cardboard

MODEL 11

Technical specifications

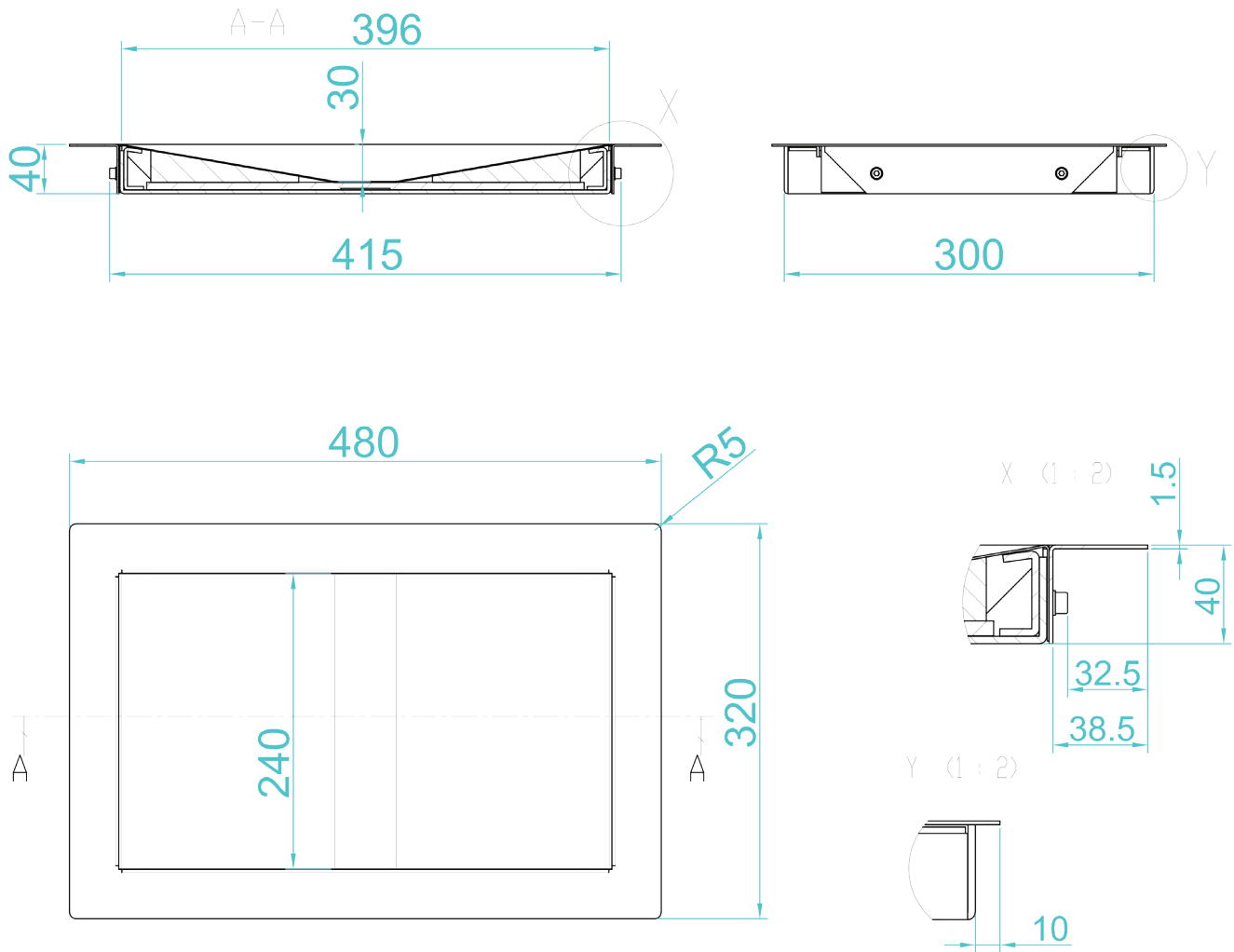



www.hygiaphone.fr

