

FRONT-OPENING-COUNTERS



Secure transfers of documents and other items for a safer welcome

Front-opening counters are mainly used in sheltered outdoor areas (guard stations, welcome stations, desks, etc.). They are large enough to securely transfer both large and small documents and packets, and can provide protection against vandalism (some are even bullet-proof), offering compliance with the highest levels of certification (FB7NS). If required, certain models can be rendered fire-resistant. When used in conjunction with a full-duplex intercom system, these front-opening counters provide employees with complete protection against all kinds of physical attack, drafts and dust.

Model 52 can be used to transfer documents, coins, notes and larger objects via two secure and independent sliding drawers. They are transferred from a secure interior area to an exterior area used by the general public.

MODEL 52

Reference:

A30219 Model 52

without intercom system

A30191 Model 52.01 + intercom system

A30223 Model 52 S (with space for Thalès Pin Pad)

A30193 Model 52.01 + intercom system and space for Thalès Pin Pad

A30441 Model 52.01 3S (with 3rd universal Pin Pad drawer)



FB4



DO YOU KNOW?



Other models in the front-opening counter range

- PMS-BE (vandalism proof)
- Model 50 (vandalism proof)
- Model 53 (FB4 level bullet-proof)
- Model 54 (FB7 level bullet-proof)
- Model 63 (FB6 level bullet-proof)

MODEL 52

Specifications

Model 52.01/ Model 52.01 S with space for Pin Pad

- 2 drawers.
- Small upper drawer (stainless steel) with receptacle for transferring coins/notes, supplied with a holding flap for securing the unit in the wind (all models).
- Model without space for a Pin Pad (52.01): in its open position, the upper drawer features a tray which can be used as a desk mat.
- Model with space for Pin Pad (52.01S): the tray is replaced by a compartment designed to accommodate the Thalès Pin Pad (*the Thalès Pin Pad referenced is the Artema desk TSC+ model. Pin Pad not supplied*). Bank cards are inserted via the front façade. Flaps to protect the Pin Pad and bank cards against inclement weather.
- Large lower drawer (RAL 8022 black lacquered steel) for transferring larger items.
- These models are delivered with a front-facing panel and an integrated intercom system.
- **Note:** Model 52 is delivered with a front-facing panel and an integrated intercom system.

Model 52.01 S certified FB4 in accordance with the EN 1522 standard

Model 52.01 3S

- 3 drawers
- Upper drawer for transferring coins and documents.
- Lower drawer for transferring parcels.
- Independent Pin-Pad drawer for the installation of all types of Pin-Pad.
- Model 52.01 3S is delivered with a front-facing panel and an integrated intercom system.

Common points

- Use: indoors or outdoors

Operation

- Drawers are manually opened by actioning the knob.
- Each drawer can be manoeuvred independently.
- In their closed position, the drawers are automatically locked in place.

Servicing / maintenance

This product requires no maintenance or lubrication.

Installation

This front-opening counter can be installed:

- in concrete walls,
- in tubular framed steel walls (e.g.: secure modular enclosures),
- in secure Fichet aluminium partitions.

A structure on which the front-opening counter can be rested is required, and on which it can be mounted using four M6 screws (pre-drilled compartment).

Description of intercom systems on a separate sheet.

Applications

- Motorway toll gates
- Service stations
- Drive-in restaurants
- Embassies
- Security posts

Advantages

- Aesthetic
- Ballistic protection for people and valuable items
- Provides protection against drafts
- Quick and easy to install
- Payment by bank card

MODEL 52

| Dimensions (mm) | 52.01 | | | 52.01S | | |
|-----------------------------|--|---|--------------------|--|--|----------------------------|
| | |  | | |  | |
| | Front panel | Body | Small/large drawer | Front panel | Body | Small/large Pin Pad drawer |
| Height | 340 | 260 | 28 / 172 | 340 | 260 | 28 / 172 / 208 |
| Width | 670 | 450 | 103 / 309 | 850 | 662 | 103 / 309 / 147 |
| Depth | 27 | 460 | 150 / 418 | 27 | 460 | 150 / 418 / 416 |
| Extension | - | - | 243 / 263 | - | - | 243 / 263 / 284 |
| Weight (kg) | 74 | | | 105 | | |
| Size of area to be reserved | Cut-out in the facade (H x W): 264 x 454 mm | | | Cut-out in the facade (H x W): 264 x 666 mm | | |

| | 52.01 | 52.01S | 52.01 3S |
|------------------------------|--------------------|--------|---------------------|
| Weight of packaging + device | 70 kg | 86 kg | 116 kg |
| Packaging dimensions | 710 x 540 x 400 mm | | 1200 x 800 x 600 mm |
| Type of packaging | Euro-pallet | | |

MODEL 52

Technical specifications

Model 52.01 52.01 S

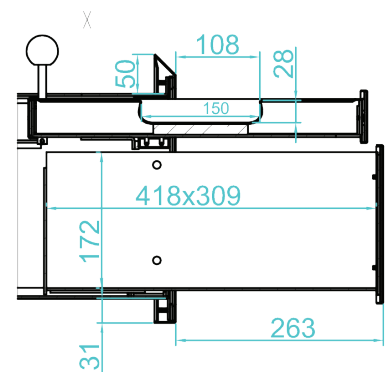
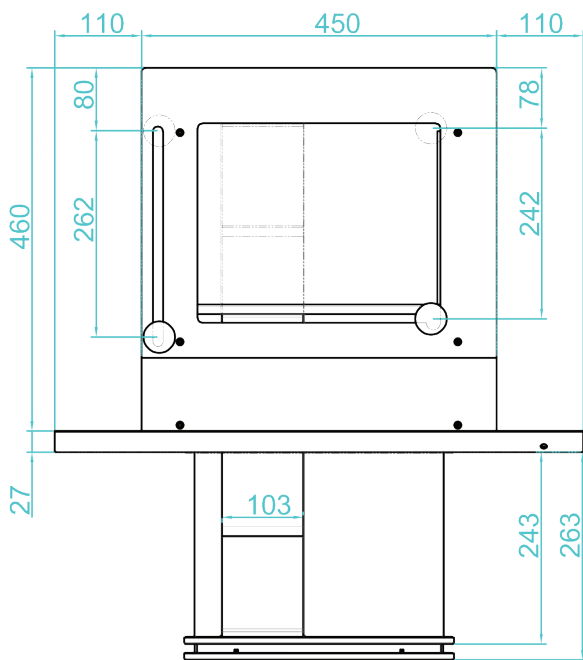
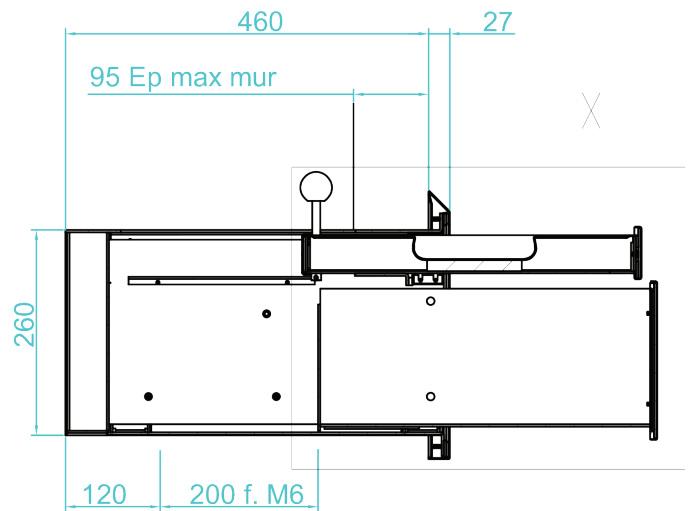
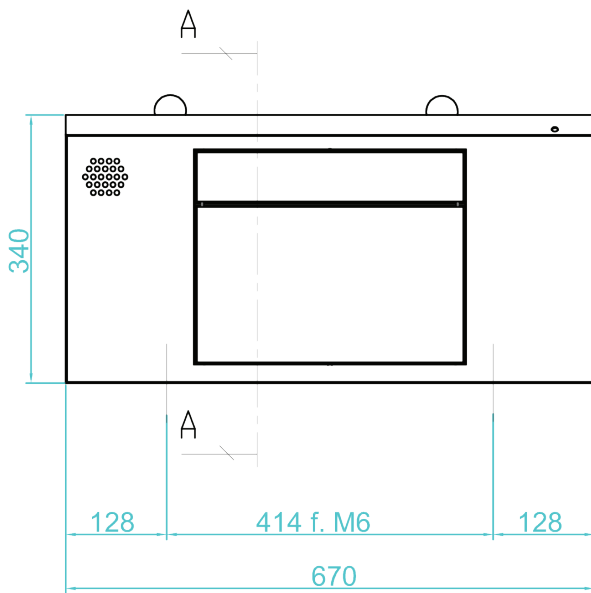

MODEL 52

Technical specifications

Model 52.01 3S

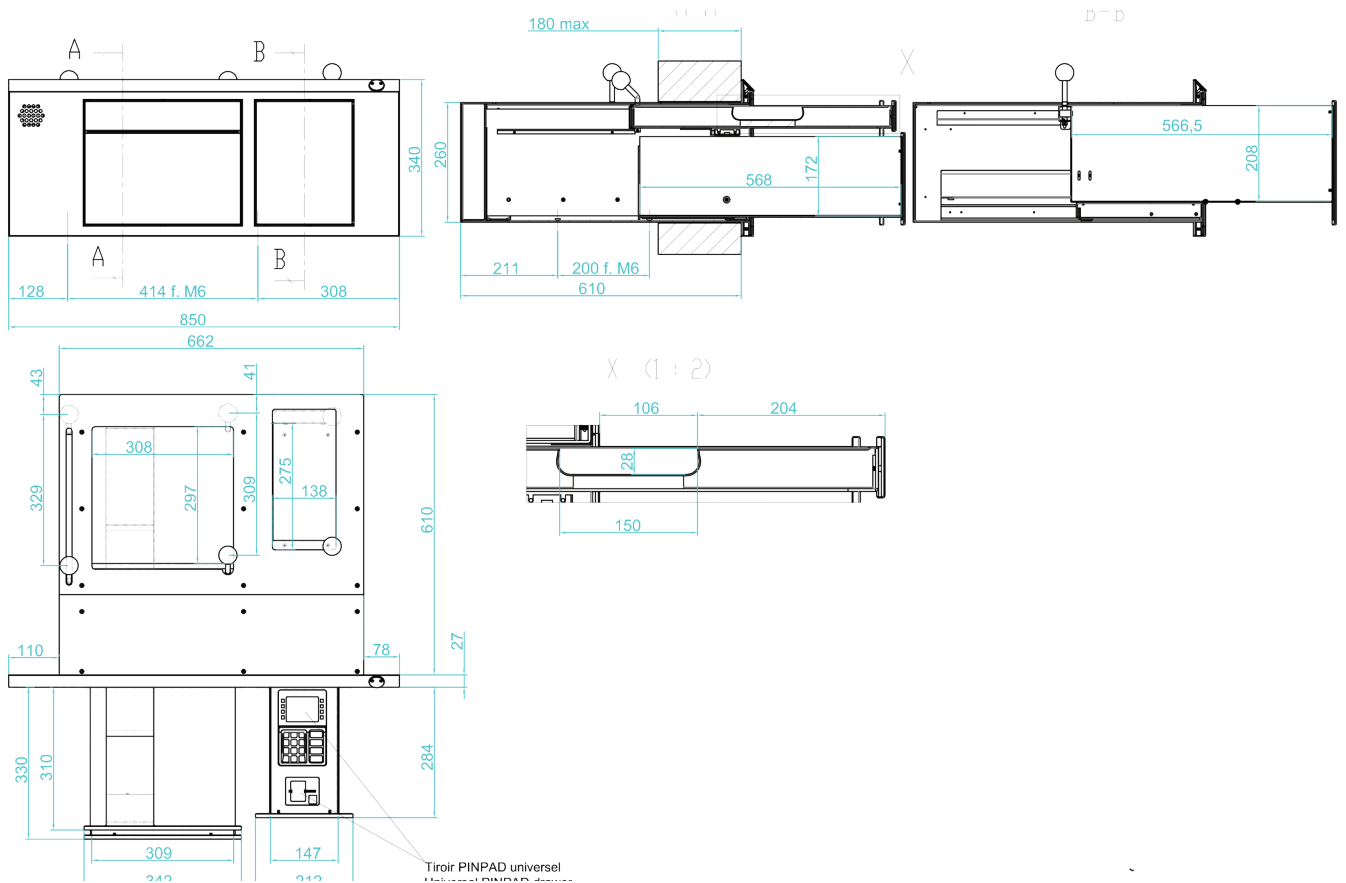



www.hygiaphone.fr

